

THE ELIASON® HCP-10 / HCG-10

# Your Durable, Versatile and Attractive Traffic Door Solution.



## HCP-10 / HCG-10 IMPACT TRAFFIC DOOR

These attractive and durable impact traffic doors are designed for use in a wide variety of applications, including grocery, retail, commercial and light industrial. The 1-½" thick door panels are constructed with a structural PVC internal framework, clad with impact resistant ABS face sheets and foamed in place with CFC-Free urethane foam for excellent insulation value. The scratch-resistant acrylic vision panels are 14" x 16" set in black rubber molding. These attractive, durable door panels are textured on both sides and operate on the Easy Swing Hinge System pioneered by Eliason more than thirty years ago, and still the smoothest-operating and most reliable hinge system on the market today. The HCG-10 has full perimeter gasketing for cooler applications.



ELIASON®

# Eliason HCG-10 / HCP-10 Doors

product features  
& specifications

## Quality Engineering Proven Over Time

- HCP-10 and HCG-10 represent the most durable impact traffic doors available for a wide variety of applications including grocery, retail, commercial and light industrial.
- Attractive textured door panels are constructed with a structural PVC internal framework, clad with impact resistant ABS face sheets available in a variety of colors.
- These doors operate on the Easy Swing Hinge System patented by Eliason.
- The HCG-10 door comes with a full perimeter edge gasket for walk-in cooler applications.

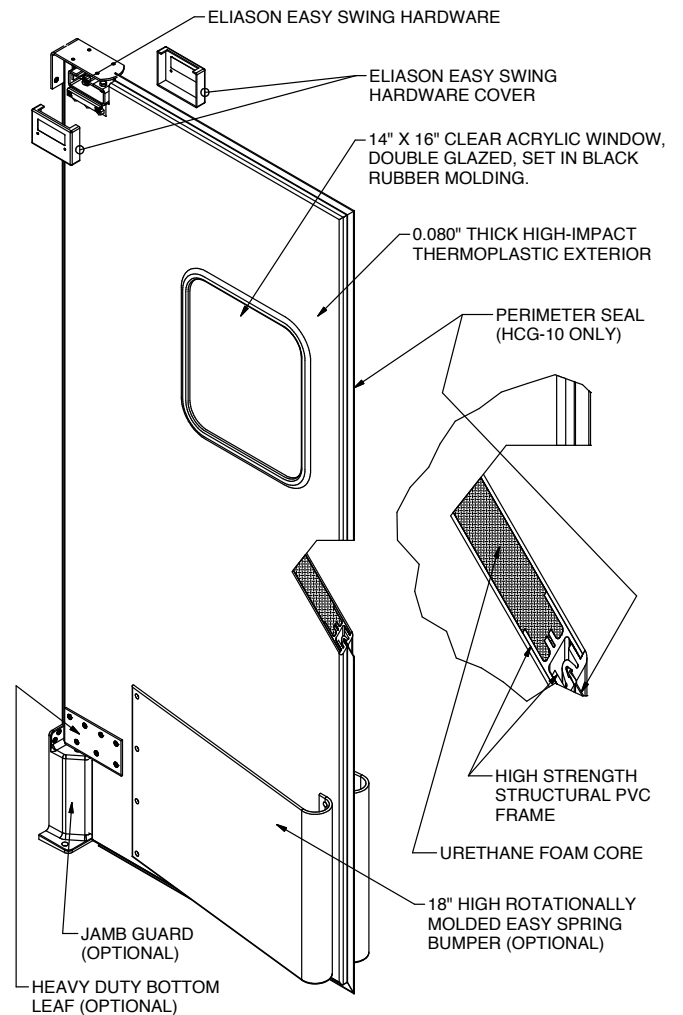

## Specifications

**DOOR BODY:** Urethane foam core with a high strength structural PVC frame, 1-1/2" total door thickness.

**WINDOWS:** 14" x 16" clear acrylic, double glazed set in black rubber molding.

**FINISH:** .080" thick high-impact thermoplastic exterior.

**HINGES:** Eliason Easy Swing® Hinge.

**EASY SPRING BUMPERS:** Standard 18" high (both sides of each door panel). Optional: 24", 36" or 42" high bumpers or scuff plates.

**HCG-10:** Same finish as the HCP-10 with perimeter seal.

**OPTIONS:** Available with optional Easy Spring Bumpers, impact plates, zinc or stainless steel jamb guards, various window sizes.

## Available Colors:

